

# **GRANZOW**® INC.



Air-Operated  
Double Diaphragm Pumps

[www.granzow.com](http://www.granzow.com)

Our Uniquely-Built Pumps Offer These Key Features:

- ① Compact design requires fewer components, resulting in lower maintenance and downtime
- ② Interchangeable modular design allows fewer spare parts inventories
- ③ Special applications can be accommodated by combining our housing and elastomer materials

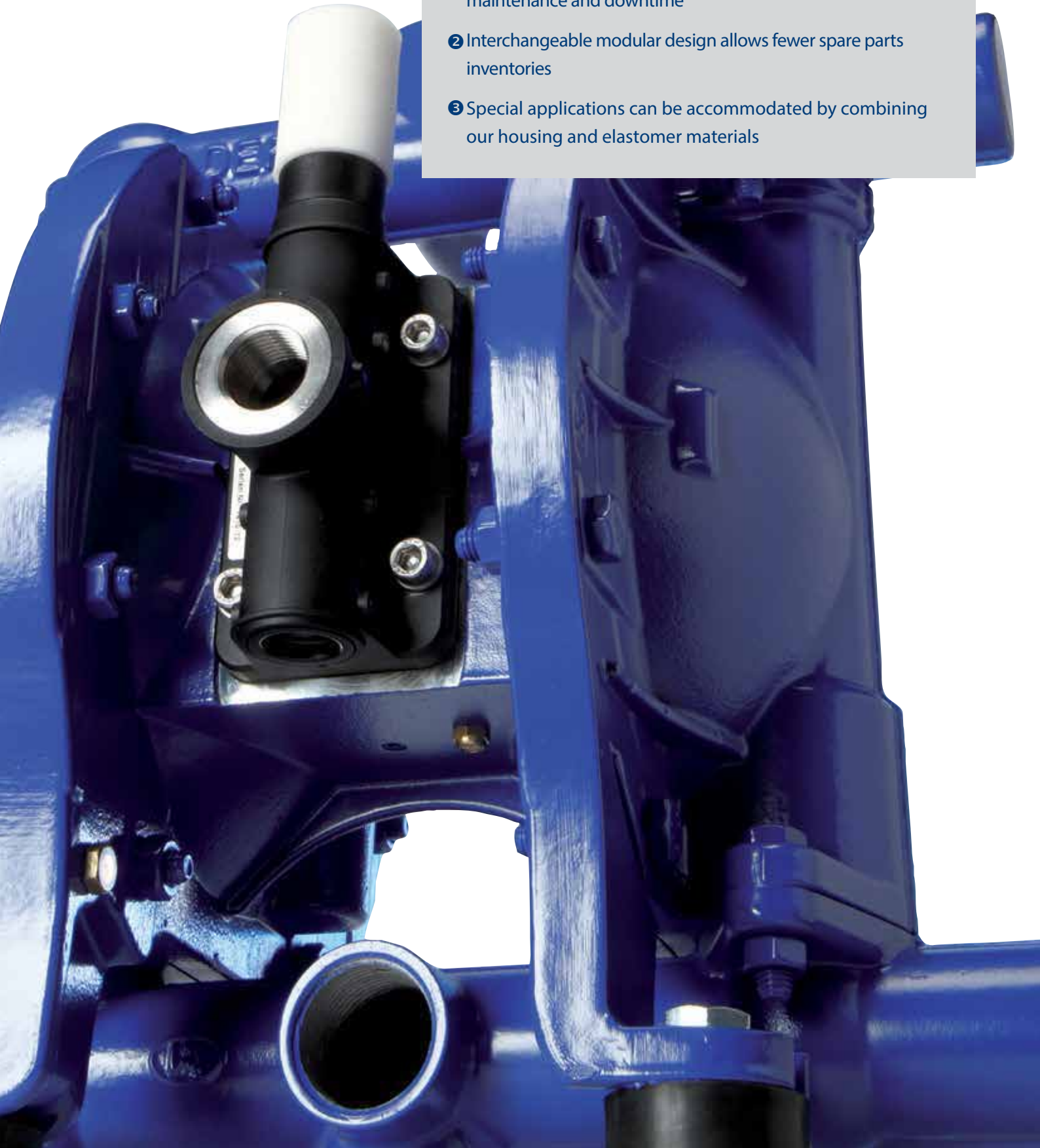

## Applications

## Air-Operated Diaphragm Pumps



### Series M Main Applications

- Automobile
- Chemical
- Ceramic and Porcelain
- Mining, Building
- Paint and Varnish
- Wastewater

### Housing Material Series M

#### Aluminium :

Multi-purpose housing material that is lightweight with versatile properties suitable for transfer of alcohols, paints, petrols, and oils.

Temperature Range:  
-10°C to +130°C

#### Cast Iron:

Robust, ductile material (spheroidal graphite) with resilient mechanical characteristics. Applicable for abrasive materials, alcohols, petrols, and oils.

Temperature Range:  
-10°C to +130°C

#### Stainless Steel:

Austenitic steel, cast, with a high level of chemical and corrosion resistance. Suitable for environments containing acids, solvents, and caustic media.

Temperature Range:  
-25°C to +130°C

\* Varies depending of the inside materials



### Series P Main Applications

- Chemical
- Galvanic and Coating
- Paint and Varnish
- Pulp and Paper
- Pharmaceutical
- Plant and Mechanical Engineering
- Power Stations and Waste Disposal Technology

### Housing Material Series P

#### Polypropylene:

Excellent chemical and corrosive resistance. Available in electrically conductive variants suitable for acids, solvents, and caustic products.

Temperature Range:  
0°C to +60°C

#### PTFE:

Thermoplastic material with superior chemical and corrosive resistance properties. Available in electrically conductive material for undiluted heavy acids and caustic media.

Temperature Range:  
-20°C to +100°C



### Series L Main Applications

- Beverage
- Biotechnology
- Chemical
- Cosmetic
- Dairies
- Food
- Medical Applications
- Pharmaceutical

### Housing Material Series L

#### Polished Stainless Steel:

Austenitic steel, forged, with a high level of chemical and corrosion resistance. Suitable for food processing and also for environments containing acids and lye.

Temperature Range: -25°C to +130°C



### Pharmaceutical and Cosmetic

Pharmaceutical and Cosmetic process applications call for demanding hygienic standards and efficient “cleanability” of system components. Our pumps accommodate these requirements with their design and polished surfaces, CIP (cleaning in place) & SIP (sterilization in place).

*(Pictured) 1" polished stainless steel pumps for hydrogen peroxide + additives in a hair colour production process*



### Food

Our pumps were designed with an unimpeded flow-path, providing smooth transfer of product, which generates minimal shear effect even with large solid content.

*(Pictured) 1 1/2" polished pump for transfer of fruit juice concentrate*



### Paint and Varnish

Paints and varnish production utilizes unique applications. Two of these applications are dosing of chemicals and mixing of paints. A commonly found process—transfer of solvents—can create an explosion-prone atmosphere. Our pumps operate safely under these conditions, and comes with full ATEX certification for your peace of mind.

*(Pictured) 3" Metallic pumps for dispersion paint for charging the filling stations*



### Tanks/Cisterns - Evacuation (or transfer between vessels)

Our pumps operate effectively in applications such as emptying of mobile and stationary tanks. Their high flow rate speeds up this process. The media transferred (pumped out) can vary from solvents and acids to alkali or other products.

*(Pictured) 1 1/2" metallic pump in a tank emptying station*



### Industrial and Chemical

The selection of available housing and elastomer materials make our pumps adaptable for most highly aggressive or corrosive media. Our pumps' outstanding chemical resistance and robust design contribute to a reliable and safe operation.

*(Pictured) 2" Polypropylene pumps for off-loading hydrochloric acid*

## Interchangeable Design

## Air-Operated Diaphragm Pumps

A key design concept of our Air-Operated Double Diaphragm Pumps is a modular, compact design. Fewer parts lead to pump efficiency thereby reducing downtime and parts inventories.

Our pumps can easily be modified to switch from one application to another simply by changing the diaphragms, balls, and seats.

**Note:**

The illustration shows the typical arrangement of the clampband version DL.

The DH version is referred to as the flanged design as the pump chambers are bolted to the centre block.

**Housing**

**Material Options**

FA	Aluminium
CA	Nodular Cast Iron
CX	Nodular Cast Iron
SA	Cast Stainless Steel 316 L
SS	Cast Stainless Steel 316 L
SX	Cast Stainless Steel 316 L
SF	Cast Stainless Steel 316 L Electro-Polished
SLV	Stainless Steel 304 Polished
SUV	Stainless Steel 316 L Polished
UEV	Stainless Steel 316 L Polished
PP	Polypropylene
PL	Polypropylene, Electrically conductive
PM	Polypropylene, Injection Molded
PV	PVDF
PT	PTFE
TL	PTFE, Electrically conductive

**Centre Block**

**Material Options**

FA, SA, CA	Aluminium
SX, CX	Bronze
SLV, SUV, UEV, SF	Aluminium, Nickel-Coated
SS	Stainless Steel (option)
PP, PM, PT	Polypropylene
PL, TL	Polypropylene, Electrically conductive



**Valve Balls**  
**Material Options**

- B NRS
- E EPDM
- F FKM
- G EPDM Grey
- N NBR
- R Stainless Steel
- T PTFE
- V NRS/Steel Core
- W EPDM/Steel Core
- X EPDM Grey/Steel Core
- Y NBR/Steel Core
- Z PTFE/Steel Core

**Valve Seats**  
**Material Options**

- B NRS
- E EPDM
- F FKM
- G EPDM Grey
- H Stainless Steel only DB
- N NBR
- R Stainless Steel
- T PTFE

**Diaphragms**  
**Material Options**

- B NRS
- E EPDM
- F FKM
- G EPDM Grey
- N NBR
- P PTFE (DH, Series L only)
- S Nopped S<sup>4</sup>® (Santoprene®)
- T PTFE
- U EPDM Grey (DH, Series L only)
- Z Nopped E<sup>4</sup>® (PTFE Compound Diaphragm)

DL = Clampband Version  
DH = Flanged Version

**DL/DH** - **25** - **SA** - **E** - **E** - **T**

Pump Type	Pump Size	Material Combination Housing/Control Block	Diaphragms	Valve Seat	Valve Balls
DL/DH	25	SA	E	E	T

### Air Valve

In applications distributed across the globe, our Air-Operated Double Diaphragm Pumps are subjected to impressive ranges of operating temperatures, pressure fluctuations, full load, and intermittent operating conditions.

This often places severe demands on the air valve responsible for the distribution of air in the individual chambers, thereby regulating the operation of the pump.

In order to meet the emerging requirements of industry, engineers conduct ongoing intensive research and development work to maintain "state-of-the-art" status for our products. Functional safety and low maintenance requirements have always been among our major guiding design principles.

Our Air-Operated Double Diaphragm Pumps can be equipped with either internal or external air control units.

### Internal Air Valve

- Reezing virtually eliminated
- No dead centre
- Low maintenance, oil-free operation
- Suitable for outside applications
- Economical
- Not affected by minor contamination of compressed air
- Durable
- Reliable



### External Air Valve

- Quickly replaceable
- Low start-up pressure
- No dead centre
- Low maintenance, oil-free operation
- Economical, suitable for all pumps
- Simple handling
- Durable
- Air saving due to virtually no leakage rate



An innovative and robust AirSave design increases the energy efficiency and service life of the pump. It delivers outstanding performance and operates at a low start-up pressure with hardly any leakage.

Shorter maintenance downtime and reduced number of spare parts decreases the operating costs.

The AirSave System is diversified for a broad range of applications. It is compatible with our Type DL-Series Polypropylen, Sizes 15/25/40 and with Type DH-Series Aluminium, Sizes 15/25/40. ATEX compliant if in combination with ATEX conforming pumps.

### Elastomer Materials (for Diaphragms)

The characteristics of various elastomer compounds are taken into account in the selection of diaphragm materials to match the chemical and mechanical requirements of particular applications.

The design of our diaphragms incorporates technological advances developed over years of field experience. Our state-of-the-art manufacturing process directly contributes to the extended lifetime of our diaphragms. A remarkable part of the process is the use of fabric that is integrated during forming within the elastomer, enhancing stability. All diaphragms can be used into ATEX conform Pumps; not applicable for EPDM Grey, Nopped S<sup>4</sup>, and FKM size 80.

#### Nopped E<sup>4</sup>® PTFE Compound Diaphragm

Key Features:



Made of high A-grade PTFE and an EPDM back up; smooth and clean surface with integrated outer piston; superior chemical resistance suitable for heavy acids and caustic products.

Applications:

All chemical (and transfer of aggressive chemicals, also in "EX-areas")

Temperature Range:

-10°C to +130°C

#### PTFE

Key Features:



PTFE diaphragm with EPDM back up; the high chemical resistance appropriate for heavy acids and caustic products.

Applications:

All chemical (and transfer of aggressive chemicals, also in "EX-areas")

Temperature Range:

-20°C to +100°C

#### Nopped S<sup>4</sup>® (Santoprene®)

Key Features:



Excellent chemical and wear resistance; optimal for acidic and caustic environments.

Applications:

All chemical and industrial

Temperature Range:

-20°C to +110°C

#### FKM

Key Features:



Elastomer rubber with good chemical resistance and applicable for hydrocarbons, acidic, and caustic media. Withstands elevated temperatures.

Applications:

Miscellaneous chemical and industrial

Temperature Range:

-5°C to +120°C

#### EPDM

Key Features:



Elastomer rubber with sound elastic properties; good chemical resistance for acidic and caustic media; frequently used with solvents and alcohols.

Applications:

Miscellaneous chemical and industrial

Temperature Range:

-25°C to +90°C

#### EPDM Grey

Key Features:



Pale elastomer rubber material with good elastic properties and viable chemical resistance for acidic and caustic products; environments with solvents and alcohols are common applications.

Applications:

Food, pharmaceutical, and beverage

Temperature Range:

-25°C to +90°C

#### NBR

Key Features:



Multi-purpose diaphragm of nitrile rubber for oily or greasy service; suitable for diverse hydrocarbons, mineral oils, grease and fuels.

Applications:

Chemical and industrial

Temperature Range:

-15°C to +90°C

#### NRS

Key Features:



Versatile multi-purpose natural rubber elastomer with good wear characteristics and elasticity, especially well-suited for abrasive products and highly diluted caustic and acidic media, and water.

Applications:

Applications with solid content, and heavy duty applications

Temperature Range:

-15°C to +70°C



## Metallic Pumps, Series M - Type DL



Our Air-Operated Double Diaphragm Pumps made of cast metal have proven themselves over decades in various industrial applications. The myriad of established applications across the globe include installations on ships, at well-known ceramics manufacturers, in spray painting systems (in the automobile industry), and in mining operations, among countless others.

The sturdy cast metal construction provides high resistance to abrasive media and a low flow resistance, owing to its polished surface. They are available in a wide selection of temperature ratings, and offer excellent corrosion resistance and a long product life.

The compact design makes the pumps easy to transport and they can be used as mobile or stationary units.

Our pumps were designed for ease of maintenance in order to minimise downtime, and they can be easily disassembled without any special tools.

Their modular design enables flexibility and restricts the need for large spare parts inventories. Our cast metal pumps can be fitted with a comprehensive assortment of accessories to match the requirements of applications. This flexibility is further enhanced by the availability of various housing and elastomer materials – extending the range of applications for which our pumps can be used.

Type	DL 15 (1/2")	DL 25 (1")	DL 40 (1 1/2")	DL 50 (2")	DL 80 (3")
CA - Nodular Cast Iron	-	●	●	●	●
CX - Nodular Cast Iron / Bronze	-	●	●	●	●
SA - Cast Stainless Steel 316L	●	●	●	●	●
SX - Cast Stainless Steel 316L / Bronze	-	●	●	●	●
SS - Cast Stainless Steel 316 L / Stainless Steel	●	●	●	●	●

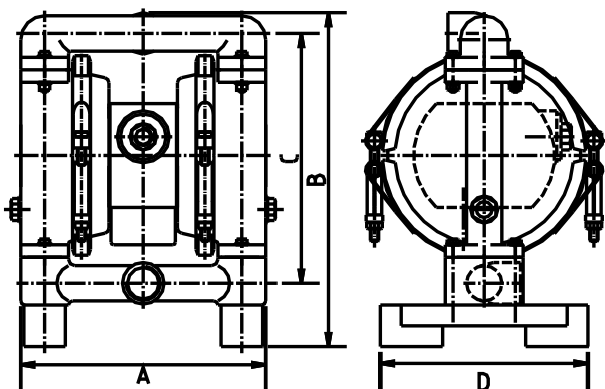

Type	Dimensions mm			
	A	B	C	D
DL 15	190	225	180	122
DL 25	236	322	241	200
DL 40	310	407	306	255
DL 50	412	540	415	340
DL 80	510	680	522	420

## Metallic Pumps, Series M - Type DH Overview



**DH® Next Generation Air Operated Double Diaphragm Pumps for industrial applications are made of cast aluminum.**

The flexible, multiport manifold can be customized to plant specifications and provides up to 25 connection options to accommodate various operational requirements.

DH® pumps feature cast feet integrated in the center block housing that enable maintenance in place (MIP). This unique design can reduce downtime by up to 25%\* and optimizes assembly and disassembly through a 30%\* reduction in required parts. Rubber feet can be easily mounted with a slotted locating hole in the center block housing.

An innovative flange design with “block-mounted” pump- and air chambers provides a safe and well-defined diaphragm clamping mechanism. The diaphragm is fixed to specifications to provide consistent lifetime wear and tear and eliminate overstretching of the pump.

Our high-efficiency flow design with Free Flow Path technology reduces unused volume with an optimized chamber for specific diaphragm design and dimensions. This technology can increase the scope of applications, accommodate particle sizes up to 25mm (DH80), and reduce the total cost of ownership through enhanced efficiency of up to 37%\*.

Pumps can be supplied with our AirSave-System, which offers low start-up pressure and a diaphragm leakage monitoring system and stroke counter sensor.

Main applications: Mechanical Engineering, Ceramics and Paint Industries, Automotive.

\*Compared to the previous model as determined by internal testing

Type	DH 15 (½")	DH 25 (1")	DH 40 (1 ½")	DH 50 (2")	DH 80 (3")
FA - Aluminium	●	●	●	●	●

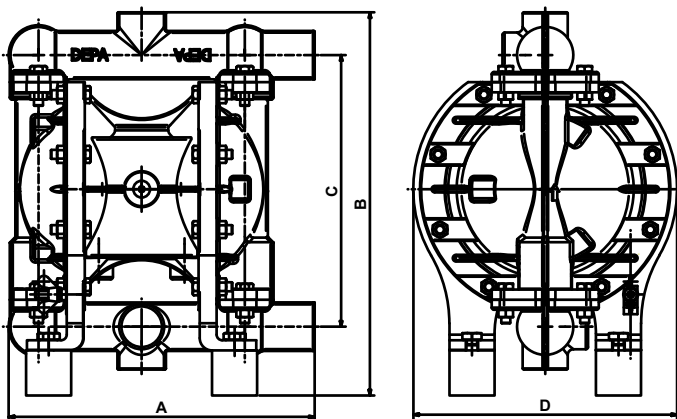

Type	Dimensions mm			
	A	B	C	D
DH15	207	266	180	174 (186) <sup>1)</sup>
DH25	272	340	241	234
DH40	370	437	307	266
DH50	502	522	414	351
DH80	568	717	522	434

1) External AirSave System

## Non-Metallic Pumps, Series P Overview



Series P made of mechanically manufactured or specially injection moulded plastic parts was designed for problem free pumping of corrosive and abrasive products in galvanic applications, in the chemical industry, and in mechanical engineering.

Mechanically stable metals do not necessarily possess the required chemical resistance needed for certain corrosive media. For applications needing such resistance, we developed our Series P air-operated double diaphragm pump versions that are made of plastic materials.

The Series P operating pressure tolerances compare with cast metal pumps, handling pressures up to 7 bar.

Computer-aided injection moulding methods deliver uniform, high quality surface finishes, minimizing flow loss while providing excellent abrasion resistance. High mechanical stability is achieved in a compact construction.

Our broad selection of construction materials allows the Series P pumps to be used in diverse applications. Internally and externally mounted air control valves are available, and our customers can choose from ANSI, DIN, and JIS flanges and threaded connections. To ensure suitability for a variety of media, wetted parts are available in numerous optional materials.

Type	DL 15 (½")	DL 25 (1")	DL 40 (1 ½")	DL 50 (2")	DL 80 (3")
PM - Polypropylene, Injection Moulded	●	●	●	-	-
PP - Polypropylene, Solid	●	●	●	●	●
PL - Polypropylene, Conductive	●	●	●	●	-
PT - PTFE	●	●	●	●	-
TL - PTFE Conductive	●	●	●	●	-

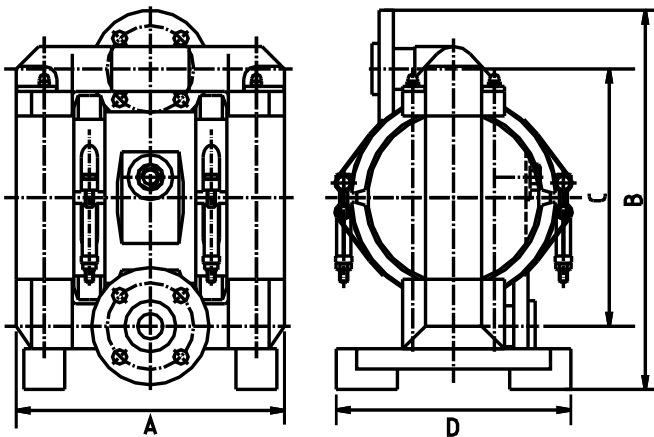

Type	Dimensions mm			
	A	B	C	D
DL 15	212	293	185	195
DL 25	263	372	252	230
DL 40	353	489	334	255
DL 50	450	622	448	340
DL 80	558	785	578)	420

## Stainless Steel Pumps, Series L Overview



**Series L pumps are made of high-gloss polished stainless steel developed for applications in food, pharmaceutical, cosmetic, and beverage industries.**

Our Series L pumps meet relevant industry standards applicable to housing materials (stainless steel), surface quality (up to 0.5 µm), and approved elastomer materials (FDA).

Clean In Place (CIP) and Sterilize in Place (SIP) standards are not uniform throughout the world, and our pumps were designed to take into account regional requirements. Consequently, we have made our pumps available in polished stainless steel 304 or 316L, with high-gloss clamp bands, and as a DH-UE version in a flanged construction design.

By using a large ball valve clearance, our pumps can handle media containing solids, such as pieces of fruit, meat or vegetable, without suffering damage.

Pumps can be supplied with connections for fluids, such as DIN11851, DIN 11864, Triclamp, Neumo or SMS, as required by the application. Some models are supplied with a height-adjustable bright polished frame.

Type	DL 15 (½")	DL 25 (1")	DL 40 (1 ½")	DL 50 (2")	DL 80 (3")
<b>DL-SF</b> - Cast Stainless Steel 316 L Electro Polished	● <sup>1)</sup>	● <sup>1)</sup>	● <sup>1)</sup>	● <sup>1)</sup>	● <sup>1)</sup>
<b>DL-SLV</b> - Stainless Steel 304 Polished	-	●	●	●	●
<b>DL-SUV</b> - Stainless Steel 316 L Polished	-	●	●	●	-
<b>DL-UEV</b> - Stainless Steel 316 L, Ra<0,8µm Electro Polished	-	●	●	●	●
<b>DH-UEV</b> - Stainless Steel 316 L1, Ra<0,8µm Electro Polished (Flanged Design)	-	●	●	●	-

**Type DH-UEV**

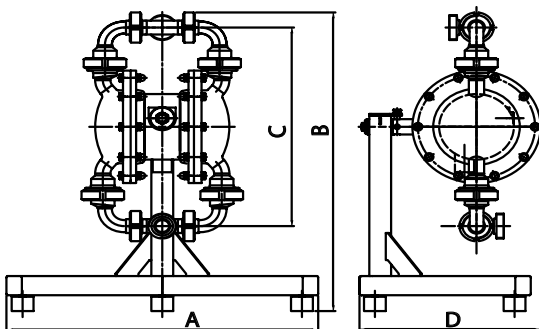

<sup>1)</sup> Not intended for use in highly critical hygienic applications, without CIP and/or SIP.

Type	Dimensions mm			
	A	B	C	D
<b>DH 25</b>	571	624	415	332
<b>DH 40</b>	571	711	575	347
<b>DH 50</b>	834	981	714	487

**Type DL-SLV**

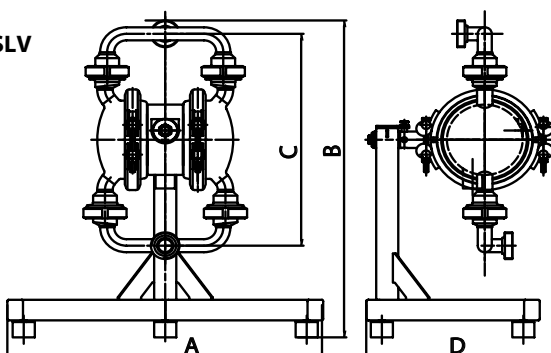

Type	Dimensions mm			
	A	B	C	D
<b>DL 25</b>	571	618	415	337
<b>DL 40</b>	571	705	575	363
<b>DL 50</b>	834	974	714	495
<b>DL 80</b>	834	1063	857	540

## Special Design Pumps, Series DP Overview



**Our Air-Operated Double Diaphragm Pumps type DP can transfer easy-to-fluidize powders economically, in a virtually dust-free and smooth process.**

In many industrial applications, powder pumps are used for rapid displacement of contents from vehicles or reusable containers, especially where transfer time and imminent mobility of vehicles/containers impact operating costs.

Our DP 125 is known to be the world's largest air-operated diaphragm pump, and it was developed in cooperation with industry. This pump has been successfully deployed over several years in special applications, providing high capacity transfer of powder.

For gentle transfer of powder the pumps are, depending on type, equipped with a Y-shaped suction and discharge manifolds as standard, in order to significantly improve powder flow. DP pumps are equipped with an additional aeration valve on the suction side inlet to enable finely controlled regulation of the required vacuum. They may also be equipped with a complete fluidization capability.

Main applications: Manufacturing of plastic products, Basic chemistry, Pharmaceutical industry, Breweries, Food industry

Type	DP 25 (½")	DP 40 (1 ½")	DP 50 (2")	DP 80 (3")	DP 125 (5")
FA - Aluminium	●	●	●	●	●
CX - Nodular Cast Iron	-	-	●	●	-
SLV - Stainless Steel 304	-	-	●	●	-

Type DP

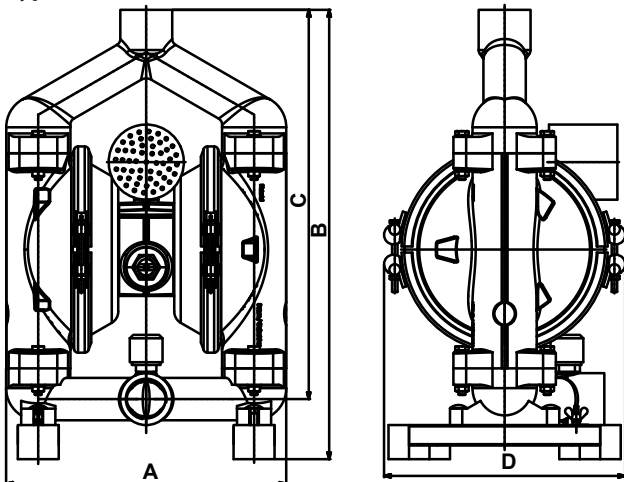

Type	Dimensions mm			
	A	B	C	D
DP 25 - FA	242	437	372	246
DP 40 - FA/CX	311	571	499	255
DP 50 - FA/CX	410	658	570	340
DP 80 - FA/CX	510	813	708	420
DP125 - FA/CX	983	1940	1370	1602
DP 80 - SLV	834	1248	1096	617

## Special Design Pumps, Series DB Overview

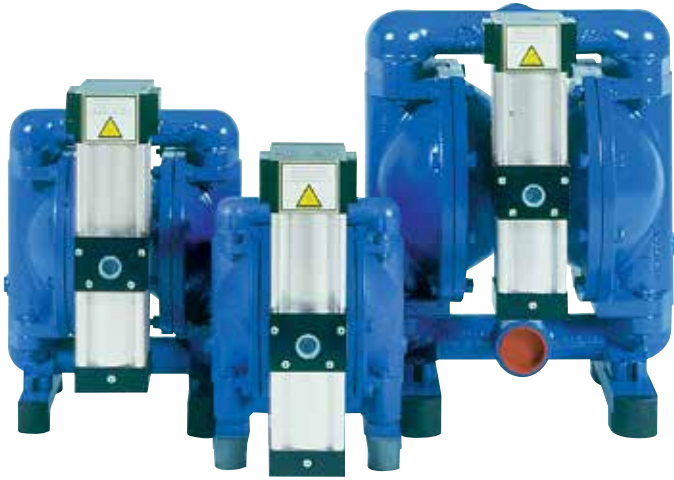

**Our Air-Operated Double Diaphragm Pumps type DB are the latest generation of high-pressure pumps.**

Industrial pressure requirements can be demanding and varied (16 or 21 bar are common), and high pumping capacities in the low pressure range (up to 7 bar) are also in demand. Our DB pumps accommodate such requirements.

DB high-pressure pumps are available in three different sizes, and are made of stainless steel. DB Pumps are designed as flanged versions to accommodate high pressures. Safety valves prevent pressure increases beyond stipulated (permitted) discharge pressures.

All high pressure pumps are fitted with a separate booster unit, which can be either directly mounted onto the pump or installed independently. Where compressed air at a suitable pressure is available, the pumps can operate without the booster. The booster increases unassisted pressure with a 3:1 ratio, without which DB pumps perform at the top range of our standard pumps (7 bar).

Main applications: Ceramic industry, Automobile industry, Wastewater industry, Chemical industry, Environmental technology.

Type	DB 15 (1/2")	DB 25 (1")	DB 40 (1 1/2")	DB 50 (2")	DB 80 (3")
SA - Stainless Steel 316 L	-	●	●	●	-

Type DB

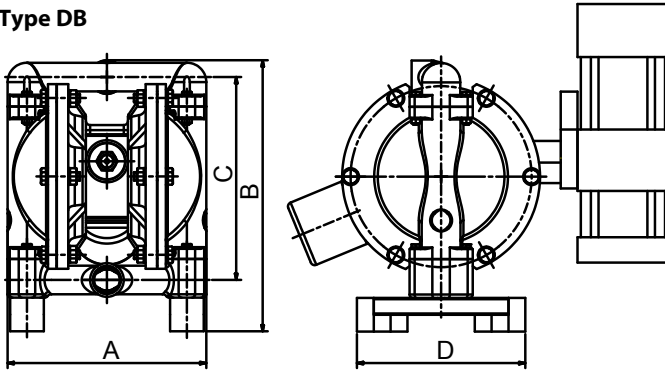

Type	Dimensions mm			
	A	B	C	D
DB 25	236	322	241	200
DB 40	310	406	305	255
DB 50	412	540	414	340

## Special Design Pumps, Series DF Overview



Our Air-Operated Double Diaphragm Pumps type DF are designed for emptying drums and containers, and provide an economical and wear resistant alternative to other pumping systems.

In order to handle a wide range of fluids, DF 25 pumps are available in alternate housing material options (e.g. aluminium, and stainless steel).

The pump can be quickly and easily mounted on the drum using our (required) drum adapter that is supplied with the pump.

Drums can be completely emptied with the supplied suction pipe. All pumps are resistant against damage due to dry running, and are "infinitely" adjustable within their performance range.

Many drum pumps can be combined with special accessories and are used by industry for dosing or as filling stations.

Main applications: Chemical industry, Waste disposal technology, Automobile industry, Furniture industry, Heavy industry

Type	DF 15 (½")	DF 25 (1")	DF 40 (1 ½")	DF 50 (2")	DF 80 (3")
FA - Aluminium	-	●	-	-	-
SA - Stainless Steel 316 L	-	●	-	-	-
SX - Stainless Steel 316 L	-	●	-	-	-
SS - Stainless Steel 316 L	-	●	-	-	-

Type DF

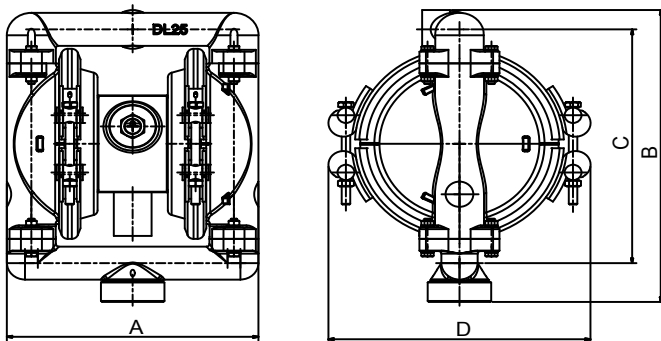

Type	Dimensions mm			
	A	B	C	D
DF 25	236	301	281	246

## Special Design Pumps, Series DZ Overview



**Our Air-Operated Double Diaphragm Pumps type DZ are mainly used in the textile and paper processing industry.**

These dual action pumps are able to transfer two different media independently and simultaneously. This is accomplished by using separate connections on the suction and discharge ports, keeping two pumped media isolated from each other, preventing unwanted mixing.

A typical application in printing and paint industries is the simultaneous supply of disparate viscous media to the production line. Economy and environmental protection concerns are thereby alleviated. All DZ pumps can be combined with accessories.

Main applications; Surface treatment technology, Wastewater technology, Printing industry, Paper processing, Furniture industry

Type	DZ 15 (½")	DZ 25 (1")	DZ 40 (1 ½")	DZ 50 (2")	DZ 80 (3")
FA - Aluminium	●	●	●	●	-
CA - Nodular Cast Iron	-	●	●	●	-
CX - Nodular Cast Iron	-	●	●	●	-
SA - Stainless Steel 316 L	●	●	●	●	-
SX - Stainless Steel 316 L	-	●	●	●	-
PM - Polypropylene, Injection Moulded	●	●	-	-	-
PP - Polypropylene, Solid	●	●	-	-	-

Type DZ

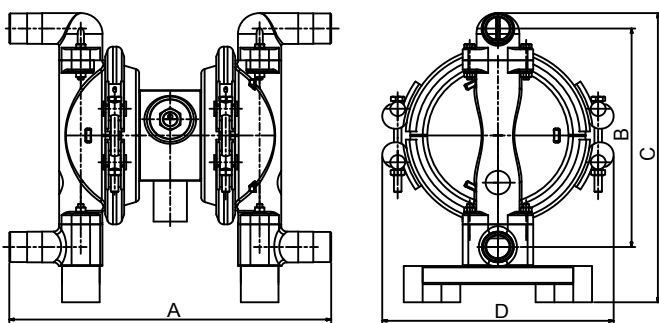

Type	Dimensions mm			
	A	B	C	D
DZ 15	282	180	223	174
DZ 25	342	241	319	246
DZ 40	454	306	403	298
DZ 50	565	414	532	356



## Accessories and Automation

### Pulsation Dampers



Active

Our Air-Operated Double Diaphragm Pumps can be equipped with an active pulsation damper mounted on the discharge manifold. This minimises any remaining pulsations.

Active pulsation dampers are particularly suitable for intermittent operating conditions and, due to their integrated control, they automatically adjust to provide an optimal degree of damping. A separate air supply is required.

As with the air-operated double diaphragm pumps, a principle guiding the development of pulsation dampers was the modular use of common components.

Pulsation dampers require minimum maintenance and are, subject to the requirements of the application, available in the same housing and diaphragm materials as the pump.

### Mobile Units

Our Air-Operated Double Diaphragm Pumps can be supplied as mobile units. Trolleys are in paint-finished steel or high-gloss stainless steel.

They can be fitted with a handle, two or four castors, a collecting basin, or other accessories as required by the customer.



Passive

As an alternative to the active pulsation damper, our Air-Operated Double Diaphragm Pumps can also be supplied with a passive pulsation damper mounted on the discharge pipe. This type is particularly suitable for uninterrupted operating conditions.

Passive pulsation dampers are available in several housing materials - painted steel, polypropylene, or stainless steel - and, depending on the design, can be fitted with an internal diaphragm. An appropriate pulsation damper can be selected based on pump size to minimise pulsations.

### Stroke Counter



The stroke counter sensor counts each cycle of the diaphragm movement. Multiplying the number of cycles with the pump chamber volumes, the discharge flow rate can be determined. For dosing applications, the stroke counter provides for precise measurement and accurate regulation.

The stroke counter sensor is located within the center block and provides an electrical

### Diaphragm leakage monitoring system



In case a diaphragm failure occurs, the pumped medium enters the air chamber and triggers the sensor. The sensor sends subsequently an electrical output to the monitoring device for evaluation of the signal. The control unit switches off the air supply to the air valve and thus halting the operation of the pump.

Two sensors per pump (one per chamber) are installed.

Two types of sensors are available:

- Conductivity Measurement, Standard (orange) for conductive products
- Capacity System, ATEX (blue) for non-conductive products and approved for ATEX-certified pumps.

output each time the diaphragm is in the end position.

The stroke counter consists of a sensor and an electronic amplifier/ regulator. the sensor can be used in ATEX certified pumps.

## Accessories and Automation

### Slow Start Up Valve



For pumps that have not been primed for operation, the unthrottled opening of the compressed air supply can create severe loads on housing materials and diaphragms, resulting in a unwanted wear. These pressure shocks can be mitigated by increasing operating pressure in a slow and gradual manner. To automate this process, we have produced our Slow Start-Up Air Valve that can be used with all of our pumps.

### Air Service Units



If available compressed air is "unfiltered," our Air-Operated Double Diaphragm Pumps should be fitted with an upstream service unit. The special filter in our Air Service Units cleans the compressed air by removing residues of water and oil droplets. The integrated pressure regulator maintains the working pressure at a stable level, unaffected by pressure fluctuations in the main air supply.

### Flanges, Fittings, Quick Couplings



Our Air-Operated Double Diaphragm Pumps can be equipped with a range of accessories, including couplings, flanges and fittings.

Depending on the type of pump, these can be supplied in aluminium, brass, stainless steel, or plastic.

### Suction Pipes



Our Air-Operated Double Diaphragm Pumps can be fitted with a suction hose and various types of suction pipes to handle liquid or powder media.

Depending on the application, suction pipes are available with or without aeration, in various lengths, in steel or stainless steel.

### Suction Filters



Our Air-Operated Double Diaphragm Pumps series M can be fitted with a suction filter connected to the inlet side for handling slurries. Filters are available in steel or stainless steel for all pump sizes.

### Suction and Discharge Hoses



Our Air-Operated Double Diaphragm Pumps can be fitted with suitable suction and discharge hoses. These are available in nominal sizes ranging from 1" to 4" diameter. They can be connected with "quick couplings" (or other accessories). All hoses are pressure tested. The product range includes standard spiral hoses with plastic or steel reinforcement, hoses for chemical applications, and hoses approved for food applications.

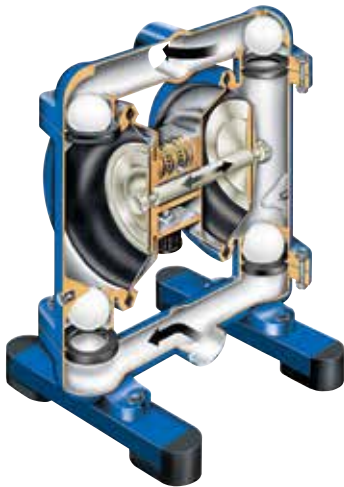

### Operation

Our Air-Operated Double Diaphragm Pumps work on the principle of oscillating positive displacement, with two back-to-back pump chambers. Both are divided by a diaphragm into an air and a fluid region. The two diaphragms are connected by a piston rod, creating the effect that during one cycle medium is expressed out of one pump chamber while medium is being drawn into the other pump chamber. The four drawings depict the sequence of a complete cycle consisting of suction and pressure strokes, showing an empty and a "full" air-operated diaphragm pump. The medium is presented in colour (red/green), for ease of demonstration.

- red = medium in suction condition
- green = medium in discharge condition

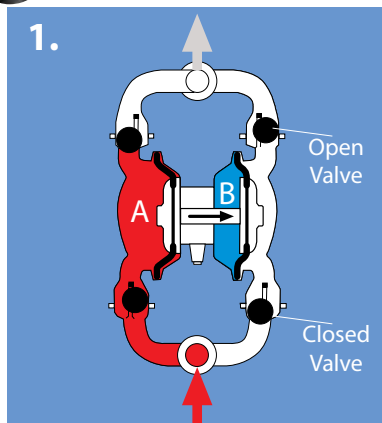

1. On start-up, pressurized air in region B (acting via connected diaphragms) lowers the pressure in chamber A.

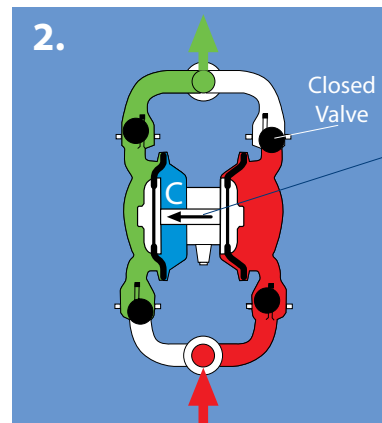

2. Pressurized air in region C acts on the diaphragm to displace product out of the pump.

End positions of inner pistons switch the control valve between alternating phases.

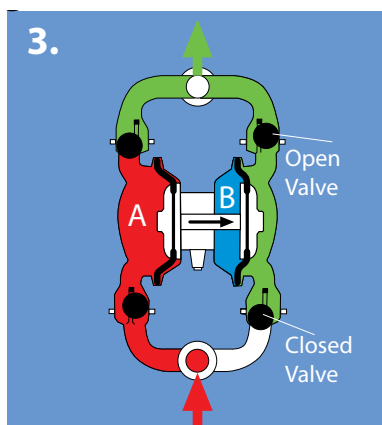

3. The process continues by again creating pressure in region B, this time expelling product from the pump while drawing in new product into chamber A where simultaneously a low pressure had been generated.

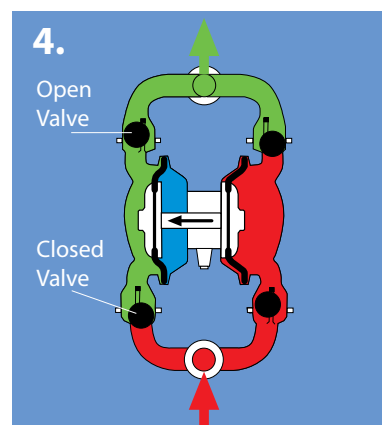

4. The cycle repeats by alternately producing pressure in regions B and C while the pump is in operation.

### Selection

To select the right pump for your application, the following factors should be considered to achieve economy of operation, long pump life, and minimal maintenance costs:

- The nature of the medium to be pumped, its viscosity, and the solids content (proportion to total content)
- Pumping capacity in relation to the desired output (per unit of time)
- Suction and pressure conditions

Considering these parameters, an optimal pump size is selected when the intersection of the intended installation "pressure vs. flow rate" is near the middle section of the curves. Please contact us for assistance in specifying Special Design pumps.

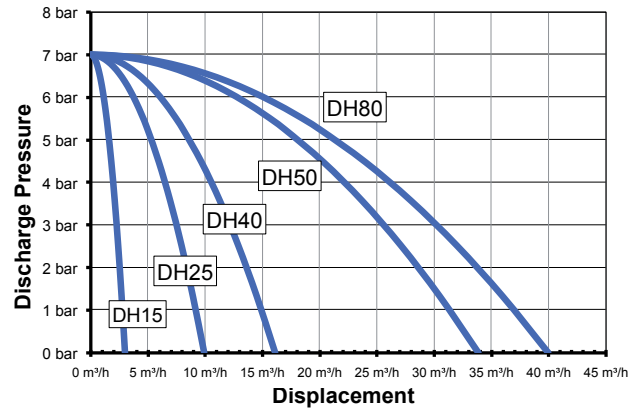

The graph is for orientation purposes only.

### Capacities with Specified Suction Lift

All of our Air-Operated Double Diaphragm Pumps are self-priming. There is a difference between "dry" (without medium) and "wet" (with medium) priming. When calculating the pumping capacity, the specific gravity of the product and the respective suction lift must be taken into consideration. Furthermore, losses attributed to piping or hoses on the suction side and the specific properties of housing and diaphragm materials must also be factored in.

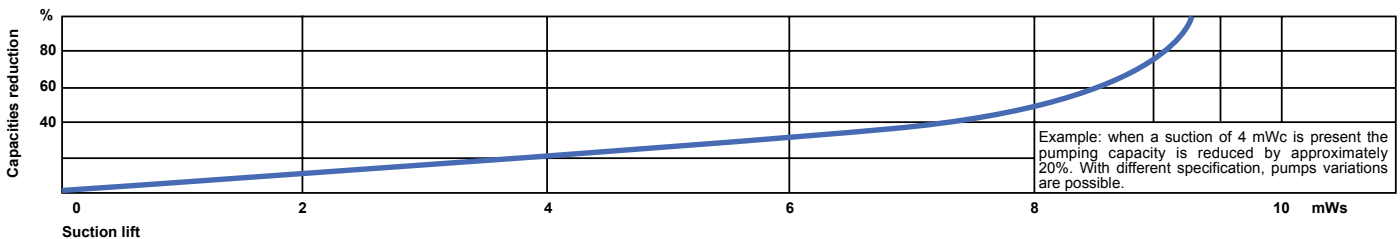

### Capacities with Viscous Fluids

All capacity curves shown in the diagram are related to water (1 mPa·s). In order to determine the appropriate pump capacity for viscous media, the realized capacity reductions shown in the diagram must be considered in relation to the known viscosity. In addition, factors such as product flow properties, length and cross-section of piping or hoses on suction and discharge sides, and valve and pump sizes with their specific characteristics must be taken into account.

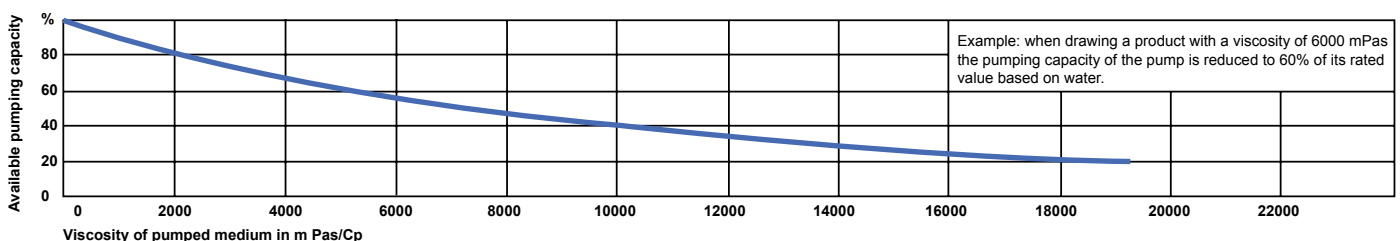

### Installation

Our Air-Operated Double Diaphragm Pumps are suitable for an endless variety of applications and are not restricted to only certain industries or processes. Our pumps can be deployed in stationary (fixed) installations within a process flow system, or used as portable or mobile units that can be transported to where it is to be used.

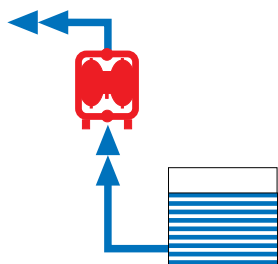

#### Self-priming pump

Our Air-Operated Double Diaphragm Pumps are dry self-priming. Depending on the pump specification a suction lift of up to 9 mWC can be achieved with a filled suction pipe.

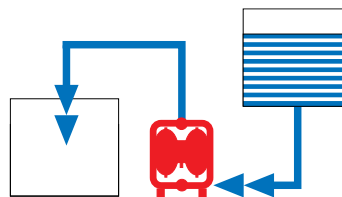

#### Pump with positive suction

Depending on the pump type, the suction side inlet pressure may need to be limited to a max. pressure 0.7 bar. In such cases a valve is required to isolate the suction pipe.

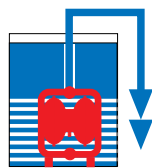

#### Sub merged pump

Our Air-Operated Double Diaphragm Pumps can be totally submerged in the pumped medium. The chemical compatibility of the pump material must be checked beforehand. The exhaust outlet must remain above the fluid level.

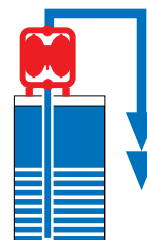

#### Pump for drums

Our Air-Operated Double Diaphragm Pumps of type DF 25 can be directly mounted on drums or containers. For ease of use the pump is mounted on the container complete with adapter. The suction pipe is supplied with the pump.

### Air-Operated Double Diaphragm Pumps Key Features:

- gentle conveyance of liquid or viscous products
- ideal for abrasive, viscous, and shear sensitive media
- can handle media with entrained solids
- tolerant of dry running
- no dynamic or pressure loaded seals
- mobile, easy to transport units
- infinite regulation of pumping capacity
- dry self-priming
- can run against closed valves
- modern compressed air control, low maintenance
- submersible designs
- also suitable for use in explosive and hazardous areas
- operation and maintenance friendly