

Key Features

Air-Operated Diaphragm Pumps

Our Uniquely-Built Pumps Offer These Key Features:

- ❶ Compact design requires fewer components, resulting in lower maintenance and downtime
- ❷ Interchangeable modular design allows fewer spare parts inventories
- ❸ Special applications can be accommodated by combining our housing and elastomer materials

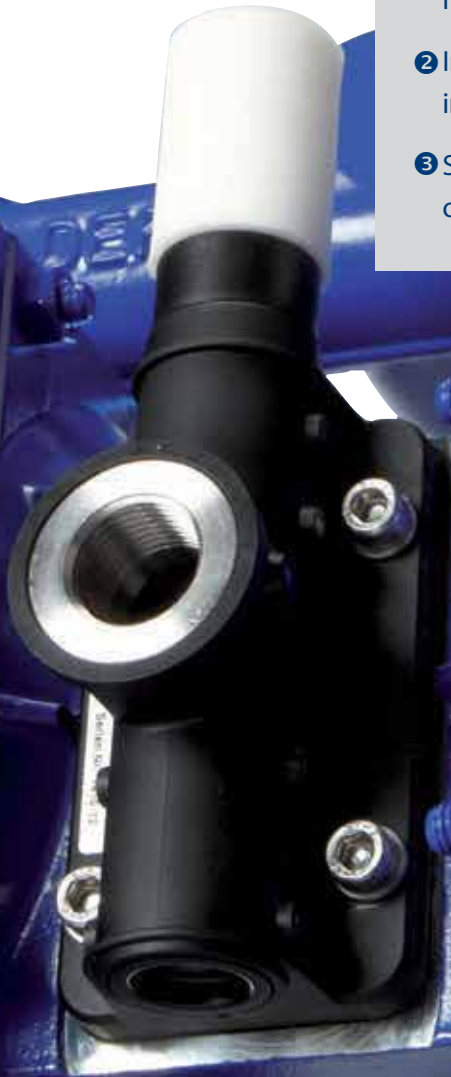

Metallic Pumps, Series M - Type DH Overview



DH® Next Generation Air Operated Double Diaphragm Pumps for industrial applications are made of cast aluminum.

The flexible, multiport manifold can be customized to plant specifications and provides up to 25 connection options to accommodate various operational requirements.

DH® pumps feature cast feet integrated in the center block housing that enable maintenance in place (MIP). This unique design can reduce downtime by up to 25%* and optimizes assembly and disassembly through a 30%* reduction in required parts. Rubber feet can be easily mounted with a slotted locating hole in the center block housing.

An innovative flange design with “block-mounted” pump- and air chambers provides a safe and well-defined diaphragm clamping mechanism. The diaphragm is fixed to specifications to provide consistent lifetime wear and tear and eliminate overstretching of the pump.

Our high-efficiency flow design with Free Flow Path technology reduces unused volume with an optimized chamber for specific diaphragm design and dimensions. This technology can increase the scope of applications, accommodate particle sizes up to 25mm (DH80), and reduce the total cost of ownership through enhanced efficiency of up to 37%*.

Pumps can be supplied with our AirSave-System, which offers low start-up pressure and a diaphragm leakage monitoring system and stroke counter sensor.

Main applications: Mechanical Engineering, Ceramics and Paint Industries, Automotive.

*Compared to the previous model as determined by internal testing

Type	DH 15 (½")	DH 25 (1")	DH 40 (1 ½")	DH 50 (2")	DH 80 (3")
FA - Aluminium	●	●	●	●	●

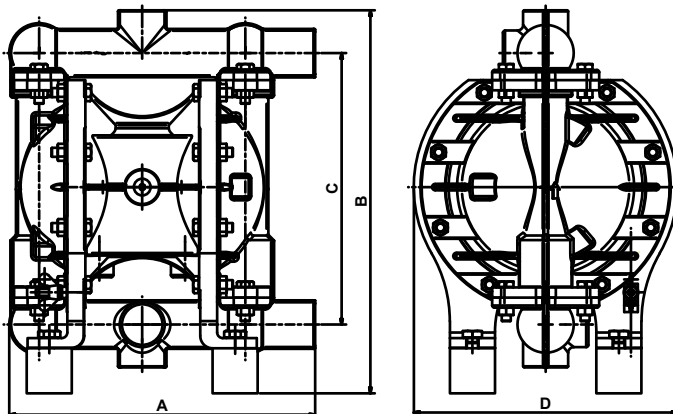

Type	Dimensions mm			
	A	B	C	D
DH15	207	266	180	174 (186) ¹⁾
DH25	272	340	241	234
DH40	370	437	307	266
DH50	502	522	414	351
DH80	568	717	522	434

1) External AirSave System

Features and Benefits

DH[®] Next Generation Air Operated Double Diaphragm Pump Series DH15, DH25, DH40, DH50 and DH80 are made of cast aluminum developed for industrial applications.

Flexible Multiport-Connections

- A customized manifold design that improves ball valve guidance, increases functionality and provides up to 25 different installation options
- Error free assembling in combination with single-center block
- Multi-porting provides many options for installation e.g.:
 - Vertical orientation can be easily used for emptying of drums
 - No additional adapters are necessary



Innovative Flange-Design

- "Block-mounted" pump and air chambers provide a safe and well-defined diaphragm clamping mechanism. The diaphragm is fixed to its specifications to provide consistent lifetime wear and tear and eliminate overstretching of the pump
- Outer rim of diaphragm is held like an O-ring with exactly defined position and deformation, due to block bolted pump chamber
- Improved leakage tightness, through consistent diaphragm fixture
- No alignment needed for pump chamber and center block

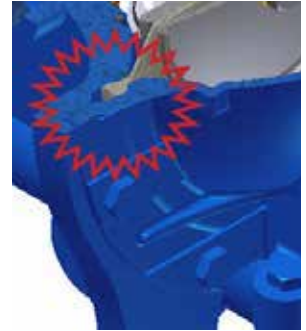

Maintenance In Place (MIP)

- Cast feet integrated in the center block housing enable maintenance in place that can reduce downtime by up to 25%*, decrease the number of required parts by 30%* and eliminate the need to remove the pump for maintenance
- Optimized for error-free dis- and reassembling, also for built-in situation
- Rubber feet can easily be mounted due to slotted locating hole in the center block housing



High Efficiency

- Flow design with Free-Flow-Path technology can accommodate particle sizes up to 25mm (DH80), increase the scope of applications and reduce the total cost of ownership through enhanced efficiency of up to 37%*
- Reduced dead volume as the shape of the chamber has been optimized for the diaphragm design and dimensions
- Additionally available with AirSave System with a low starting pressure
- Have been optimized for low noise emissions and high leakage tightness in industrial applications

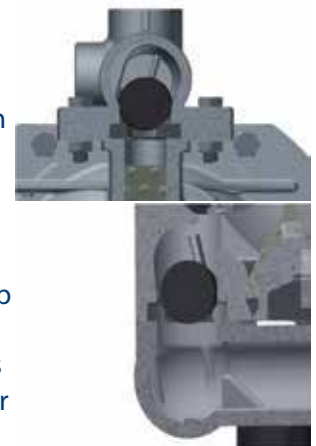

*Compared to the previous model as determined by internal testing

Applications

The aluminum housing material with universally selectable interior allows versatile application possibilities. For instance in

- Painting- and coating industries
- Printing- and gluing machines
- Mechanical engineering and construction
- Automotive

Sizes

DH[®] Next Generation Air Operated Double Diaphragm Pumps of aluminium series are available in nominal sizes of 1/2" (DH15), 1"(DH25), 1 1/2" (DH40) 2" (DH50), and 3" (DH80). Equipped with AirSave System or internal air-valve.

	Size				
	15	25	40	50	80
Suction height (m), dry ¹⁾³⁾	2,5	6,0	6,0	6,0	6,0
Max. solid size (mm)	3,5	10,0	16,0	18,0	25,0
Weight (kg)	2,0	8,2	12,0	35,4	55,0
Min. start-up pressure (bar)	0,5 ²⁾	0,5 ²⁾	0,5 ²⁾	1,5	1,5

1) At 2 bar air pressure (DH15/25), 7 bar (DH40)

2) AirSave System (M-valve)

3) For valve seat/valve ball combination of PTFE or stainless steel the suction height will be reduced

Marking and Identification

The pumps are provided with a nameplate which the pump code, serial number, date of manufacturing, max. allowed temperature and pressure.

The pump coding gives all information about size, material and equipment which allows accurate for linkage to spare parts.

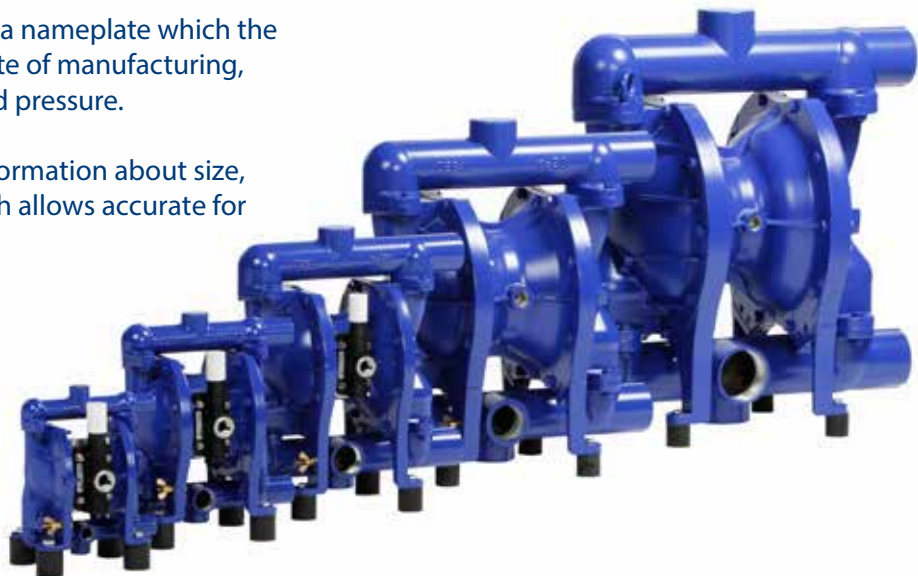

Temperature

Operation temperature of aluminum -10°C to +130°C. Further limitations are according to interior of pump, see table with product wetted interior

Product wetted interior	Max. Temperature (°C)
NBR	-15 to +90
EPDM	-25 to +90
NRS	-15 to +70
FKM	-5 to +120
DEPA nopped S ⁴ ®	-20 to +110
PTFE	-20 to +100
DEPA nopped E ⁴ ®	-10 to +130

Applied Guidelines

- ATEX compliant in accordance with directive 94/9/ EC equipment group II, category 2GD, Explosion group IIB Tx (II 2 GD IIB Tx)
- Machinery Directive 2006/42/EC



ATEX-compliant II 2GD IIB Tx

Pump Sizes and Equipment

DH 25 - FA B S E T

Connecting Dimension DH (mm) / inch	Housing Material
15 / 1/2"	Aluminium
25 / 1"	Aluminium
40 / 1 1/2"	Aluminium
50 / 2"	Aluminium
80 / 3"	Aluminium

Material Options			
Material	Diaphragm	Valve Seat	Valve Ball
NBR	N	N	N ¹⁾
EPDM	E	E	E ¹⁾
NRS	B	B	B ¹⁾
FKM	F	F	-
DEPA nopped S ⁴ ®	S	-	-
PTFE	T	T	T
DEPA nopped E ⁴ ®	Z	-	-
Stainless Steel	-	R	R
NBR with core	-	-	Y ¹⁾
NRS with core	-	-	V ¹⁾

1) Not for size 15

Further material options are available upon request

Product Ports / Orientation of Manifolds						
		Discharge Port				
		D1	D2	D3	D4	D5
		(outlet to the top)	(outlet at opposite side of air inlet)	outlet right hand side / view to air inlet)	(outlet at same side as air inlet)	(outlet left hand side / view to air inlet)
Suction Port	S1 (inlet from bottom)	A	B	C	O ¹⁾	P
	S2 (inlet aligned with air inlet)	D	-	E	Q ¹⁾	R
	S3 (inlet right hand side / view to air inlet)	F	G	H	T ¹⁾	U
	S4 (inlet at opposite side of air inlet)	I	J	K	W ¹⁾	X
	S5 (inlet left hand side / view to air inlet)	L	M	N	Y ¹⁾	Z

1) Not valid for DH15/DH25 with AirSave System

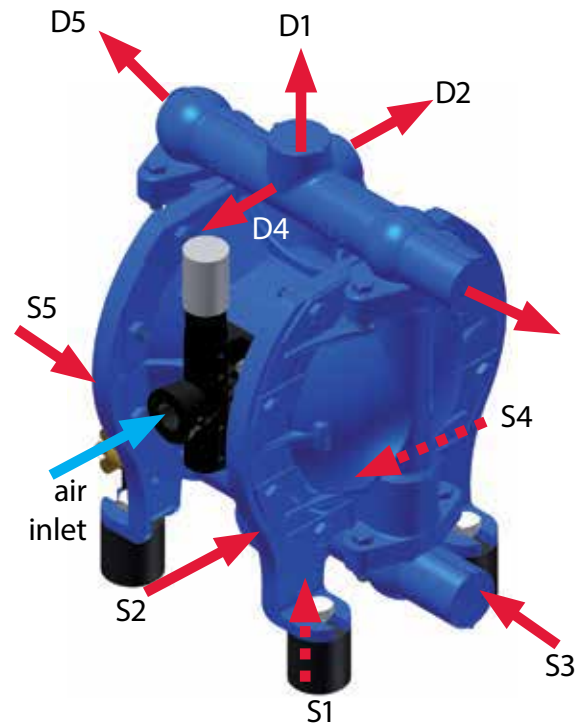

D = Discharge Side
S = Suction Side

Dimensions

Dimensions (mm)	Size				
	15	25	40	50	80
A	136	165	182	243	296
B	207	272	370	502	568
C	180	241	307	414	522
D	266	340	437	522	717
E	52	61	80	88	105
F	34	38	50	70	90
G	99	116	116	120	120
H	116	154	206	275	340
I	89	122	155	296	367
K	174 (186) ¹⁾	234	266	351	434
L	18	23	30	18	15
M	105	134	165	226	280
Air inlet Internal Air Valve (inch)	G 3/8"		G 3/4"		
Air inlet AirSave Sytem (M-Valve) (inch)	G 1/2"		-		

1) External AirSave System

Exploded view

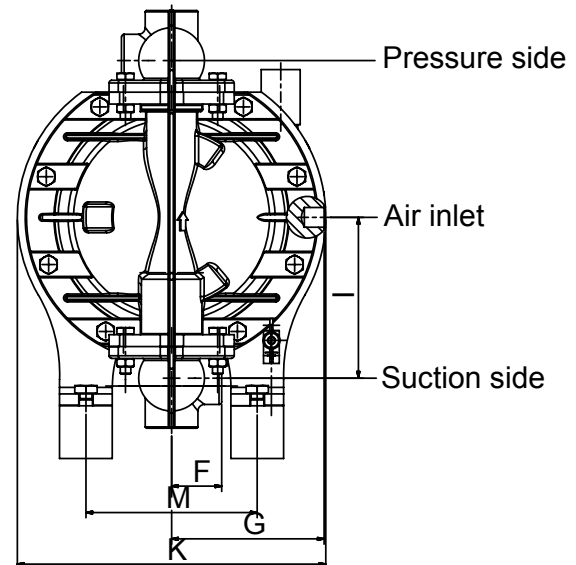
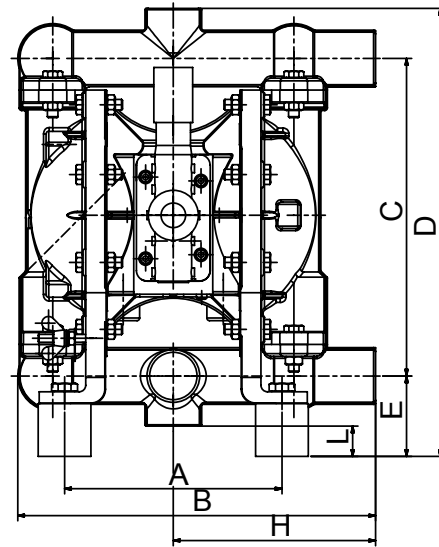
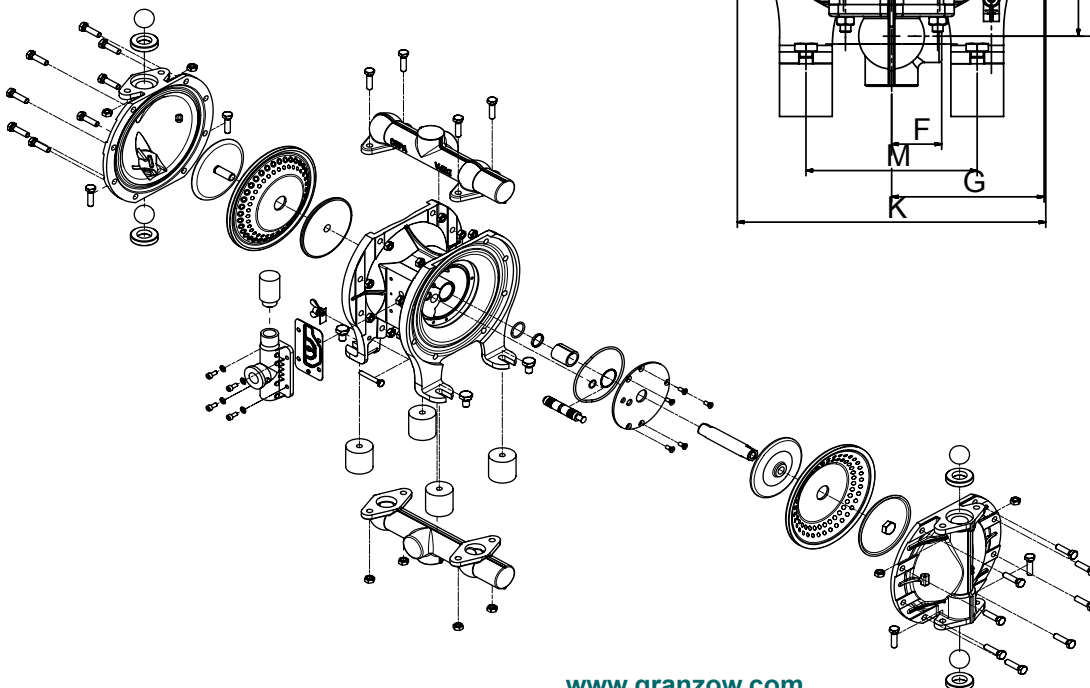

Performance Curves

Example: To help you in selecting the correct pump size.

Required pump rate is 18 GPM, required total discharge head is 43 PSI. The correct selection is DL 25; the required air pressure is 73 PSI, and the air consumption is 18 SCFM.

The indicated pumping rates are based on water.

